

SEWTECH

Innovate. Automate. Serve.

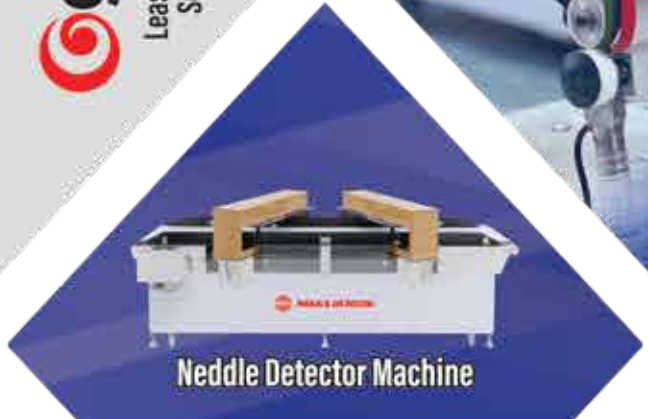

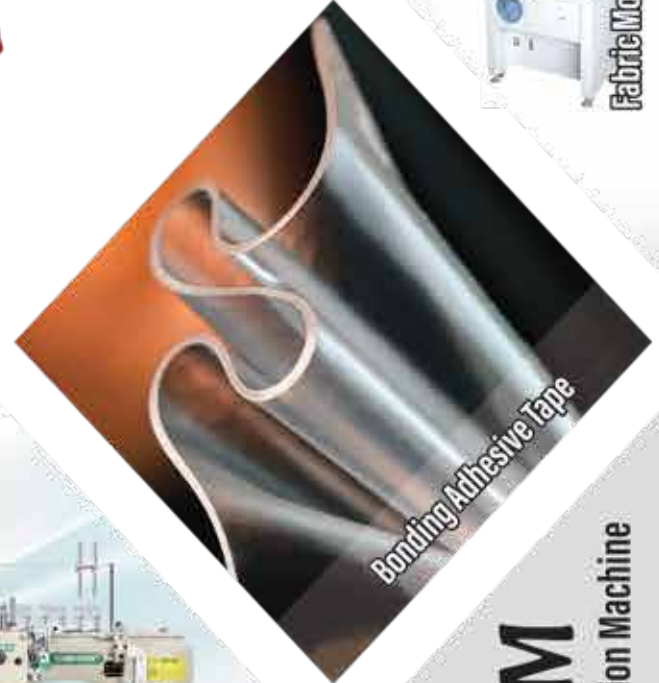

Sewtech Head with AMM Boss



Sewtech Head with Dawnshing Boss



GTB 2025



Buffer Dinner after GTB



GTB 2025



Important Clients in our office



Sewtech business head with sens.bond team



GTB 2025



Sewtech Business Head with J&C Boss



Sewtech Business Head with our Key Business Partner

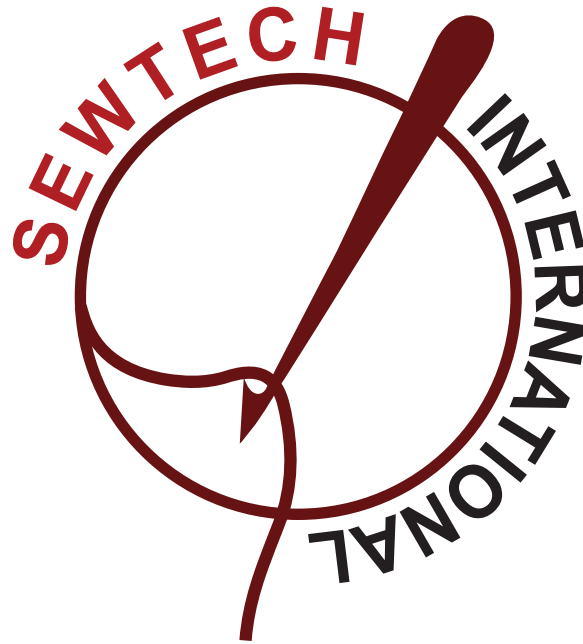

Company Informtion

Company Name: SEWTECH INTERNATIONAL

Established Date: May 2022

No of Staff: 04 nos

Business FOCUS: Supplying industrial sewing machinery and service,

Trade license no : TRD/DNCC/001221/2021

Tin certificate: 349026664131

Bin certificate: 00864598-0102

Sewtech International

📍 OFFICE: Parkway Trade Center, 4/13, Shalikchura, (Beside Asia Pump), Tongji, Gazipur, Bangladesh.

☎ +880 1748 922 485,

☎ +880 1602 050 011

✉ info@sewtechint.com

PROFILE

Welcome to Sewtech international



Sewtech International
YOUR TECHNOLOGY PARTNER

Sewtech international – offering ‘Best in Class’ sewing solution

Recognized in Bangladesh for offering high quality products and services to the apparel industry, Sewtech international is a preferred supplier of an extensive range of popular brands of industrial **sewing Automation, Seamless bonding solution, Ultrasonic Solution, Laser Cutting Solution, Bonding Adhesive Glu, Pressing Solution, UT Devices, Customize Automation & Bra molding machineries and Spare parts** to the Bangladesh.

The company also offers the following innovative and reliable solutions to the Bangladesh

- Reliable maintenance, support and expert advice on industry best practices.
- Research and development services for apparel industry requirements.
- Client resource training to improve productivity, quality and profitability.

Sewtech International

📍 OFFICE: Parkway Trade Center, 4/13, Shalikchura, (Beside Asia Pump), Tongji, Gazipur, Bangladesh.

☎ +880 1748 922 485,

☎ +880 1602 050 011

✉ info@sewtechint.com

OUR MISSION

To provide a total sewing strategy to our customers in the apparel industry by facilitating sophisticated innovative cutting edge machinery and equipment from leading international manufactures and provision of efficient and cost effective after sales service and upkeep of machinery together with offer of excellent training facilitate human resources development and research to enable them to optimize return on investment.

OUR VISION

To be recognize and respected as the clear market leader in the industry through the provision of excellence in customer service and the delivery of innovative, reliable and “best in class” solutions that continually drive for our customers

Sewtech International

📍 OFFICE: Parkway Trade Center, 4/13, Shalikchura, (Beside Asia Pump), Tongji, Gazipur, Bangladesh.

☎ +880 1748 922 485,

☎ +880 1602 050 011

✉ info@sewtechint.com

Sewtech International

OUR PRODUCT

1. SEWTECH-Brand automatic machinery

- a. Double head ring robot machine for boxers, (Knit/Woven)
- b. Overlock elastic ring making machine, (Knit/Woven)
- c. Automatic sequencer buttonhole/stitch machine for shirt placket (Ladies ware/ Shirt)
- d. Automatic Buttonhole and Stitch machine for, (Knit POLO shirt)
- e. Automatic Hang tack sticker prints and labeler machine (Multi Product)
- f. BRA rings insert machine (Lingerie)
- g. Bra wire inserts machine (Lingerie)
- h. BRA Hook and eye joint machine (Lingerie)
- i. PAD Printer machine (Multi products)
- j. Seam pull off machine (Blind stitch) (Knit, Lingerie)
- k. Automatic label cutting machine, (For all product)
- l. Automatic ribbon / Piping cutting machine (For all product)

2. SEWPOWER-Brand industrial sewing machine (Special for Knit)

3. J&C-Brand Seamless bonding machine (Lingerie/Active ware/Sports ware)

- a. Laydown
- b. Fold over
- c. Binding
- d. Seam sealing
- e. Dispenser machine (PUR Glue)

4. SENSBOND brand bonding adhesive glue (Lingerie/Active ware/Sports ware)

5. SEWTECH Bonding peel test machine, (Lingerie/Active ware/Sports ware)

6. YISHUAI Brand pressing machine (Bonding/ Shirt/Suit)

- a. Double head carousel pressing machine

7. EVERGREEN Brand Taiwan made ultrasonic solution (Lingerie/Active ware/Sports ware)

- a. Rotary type ultrasonic cutting machine
- b. Ultrasonic cutting machine
- c. Ultrasonic spot tacking machine

8. NIKKA Brand Needle detector machine (For All product)

10. GBOS Laser cutting machine (Total solution)

11. DAWNSING Brand UT devices. (UT Total solution)

12. SEWTECH Brand Devices,

- a. Bra automatic loop cut and folding device for wing operation (Woven bottom)
- b. Elastic tension/RAM devices (Lingerie/Knit)
- c. Relaxing devices (Lingerie/Knit)
- d. Fully automatic spaghetti devices, (Lingerie)
- e. Straight double buttonhole device (Bottom Knit/Woven)
- f. Automatic rope folding devices (Bottom Knit/Woven)
- g. Automatic Loop cut and feeding devices for waistband operation (Woven)
- h. Reinforcements devices (Denim)
- i. Bartack suction and chain cutter devices (Lingerie/Knit)
- j. Automatic button feeder (Knit/Woven)
- k. Single needle anti bird nest devices (Knit/woven)
- l. Bartack anti bird nest devices (Lingerie/Woven)
- m. Automatic cap hole devices, (Cap)
- n. Induction type thread trimming devices (Multi product threads long ends trimming operation)
- o. Puller devices (Multi product)
- p. Roller devices, (Multi product)
- q. Pneumatic type uncurled devices (Knit)
- r. Pneumatic type presser foot presser device, (Multi product)
- s. Sami automatic hemming folding device, (Knit)
- t. Induction type Tape cutter device(TK)(Single needle/ two needle (lock/ chain stitch), Flatlock/Flat seam/VT)
- u. Induction type loop cutting device (Denim)

13. AMM Brand customizes automation

- a. Kansai waist band skip stitch device (Denim)
- b. Sensor control eye glass switching machine on/off device (Overlock/ Bratack)
- c. Automatic Back yuck joint and top stitch,(Denim)
- d. Automatic fusing panel collecting machine, (Knit/Woven)
- e. Over lock pocket facing machine with vision system, (Denime)
- f. Paper tag folding machine(Multi product finishing)
- g. Automatic paper tag feeding and plastic stapler feeding machine, (Multi product finishing)
- h. Auto hanger feeding machine, (Multi product finishing)
- i. Automatic six label feeding and tacking machine,

14. SEWING MACHINE SPARE PARTS

15. BONDING MACHINE SPARE PARTS

16. AUTO CUTTER MACHINE SPARE PARTS

17. RIBBON CUTTING/PIPING CUTTER MACHINNE BLADE

18. AUTOMATION ELCTRONIC PARTS (PLC/PNUMATIC ITEM/SOLUNIODE), ETC

19. SPECIAL PRESSER FOOT

20. HEROIS ROTARY HOOK

21. IRON FOAM/SILICON RABBER MATE

22. ATTCHMENT/FOLDER/GUDES

Sewtech International

📍 OFFICE: Parkway Trade Center, 4/13, Shalikchura, (Beside Asia Pump), Tongji, Gazipur, Bangladesh.

☎ +880 1748 922 485,

☎ +880 1602 050 011

✉ info@sewtechint.com

Table of CONTENTS

Intro	01-06
Sewpower (Industrial sewing machine)	07-10
J&C (Seamless bonding machine)	11-15
Sens.bond (Seamless bonding adhesive tape)	16-19
Peel Test Machine	20
Evergreen (Lingerie ultrasonic solution)	21
Yishuai (Bonding Press Solution)	22-23
Nikka (Japan origin noise-reduction needle detector machine)	24
Yilli (Bra molding solution)	25-26
Funeng	27
AMM (Customize Automation)	28
Sewtech Machines (Innovate. Automate. Serve.)	29-39
Sewtech Devices (Innovate. Automate. Serve.)	40-67
Dawn Sing (Dawnsing automatic thread trimming device)	68-71
STI (Spare Parts)	72-78

OUR PARTNERS

SEWTECH

Innovate. Automate. Serve.

AMM

Customize Automation

J&C

Seamless bonding
machine

SEWPOWER

Industrial sewing machine



DAWN SING

Dawnsing automatic
thread trimming device

SENS.BOND

Seamless bonding
adhesive tape

EVER GREEN

Lingerie ultrasonic
solution

YISHUAI

Bonding Press Solution



Bra molding solution



Laser Cutting Solutions



NIKKA DENSOK LIMITED

Japan origin noise-reduction
needle detector machine

Sewtech International

OFFICE: Parkway Trade Center, 4/13, Shalikchura, (Beside Asia Pump), Tongji, Gazipur, Bangladesh.

+880 1748 922 485,

+880 1602 050 011

info@sewtechint.com

SEWPOWER

SEWPOWER Brand Automatic Machine

SP-740AMG-02-452-G2-VD/DS

步进高速曲臂式四针六线拼缝机
Stepping high-speed crank arm type four-needle six-thread sewing machine

全密封型

Fully oil-sealed design
without any oil spot

基础款

Basic



适用于一般内衣裤二片布接缝处之拼接缝和补强、男用内裤裤底过骨拼缝，女用紧身衣裤贴条补强，拼缝，双色布料完全密合拼缝等。

Applicable to two pieces fabric for flat seaming the underwear and reinforce the join place. For example, the flat seaming on cross lap of men's underpants bottom, the taping for reinforcing the chemise, the flat seaming different color fabric...etc.

型号 Model	4	6	4.8	1.6	~	1:07-1:05	8-10	30	4200
SP-740AMG-01/02	4	6	5.2						
SP-740AMG-01/02-G2	4	6	6.0						
SP-740AMG-01/02-SL	4	6	6.0						
SP-740AMG-01-G1-L	4	6	5.2 6.0 7.0 8.0	2.5		8			
SP-740AMG-01/02-G1-F			5.2			6			
SP-740AMG-01/02-G2-H			6.0						



产品特点 Features



吸布屑管组

万向可调节吸风装置，可依客户需求任意调整位置，内置进气管，吸力强劲；

Universal adjustable suction device, which can be adjusted arbitrarily according to customer needs, built-in air intake pipe, strong suction;



小筒型设计

采用小筒型设计，圆周长150mm,可车缝袖口直径70mm,车缝小口径的针织物，更加便利。

The design adopts a small tube type, a circumference of 150mm, a diameter of 70mm sleeve, and a small diameter knitted fabric, which is more convenient.



弹片式压脚

弹片式压脚机构的使用，使内衣用薄布料及高弹性面料都能轻松应对。

The design of the machine can handle thin underwear material and highly elastic material.

Sewtech International

OFFICE: Parkway Trade Center, 4/13, Shalikchura, (Beside Asia Pump), Tongi, Gazipur, Bangladesh.

+880 1748 922 485,

+880 1602 050 011

info@sewtechint.com

SEWPOWER Brand Automatic Machine

SP-1500-CB356-EWT-BJT-DS/W

步进一体迷你针板自动剪线纵筒式绷缝机
Stepper Motor Integrated Mini Needle Plate Automatic Thread
Trimming Vertical Barrel Interlock Sewing Machine



专利产品 Patented products
仿冒必究 Counterfeiting Investigate



SP-1500-CB356-EST-BJT-DS/W

■ 机器型号代码解析表
Code performance comparison

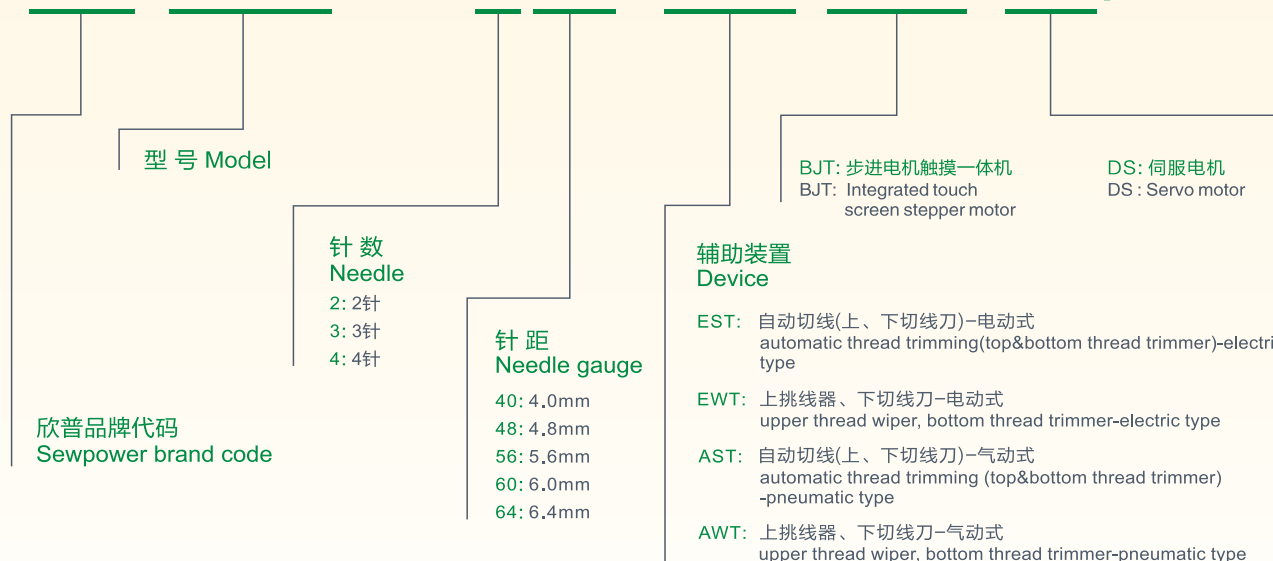

Sewtech International

OFFICE: Parkway Trade Center, 4/13, Shalikhura, (Beside Asia Pump), Tongji, Gazipur, Bangladesh.

+880 1748 922 485,

+880 1602 050 011

info@sewtechint.com

SEWPOWER Brand Automatic Machine

SP-710-CB356/EST/DS/W

Servo motor ultra-small horizontal cylinder interlock sewing machine



Sewtech International

OFFICE: Parkway Trade Center, 4/13, Shalikchura, (Beside Asia Pump), Tongi, Gazipur, Bangladesh.

+880 1748 922 485,

+880 1602 050 011

info@sewtechint.com

1

2

3

ADHESIVE FILM LAYDOWN MACHINE JC-6862



Description:

- * Upper and lower rollers adjust the speed separately
- * Blowing adjust air flow and temperature separately
- * Independent adjustment for heating tank temperature
- * Roller pressure is adjustable
- * With cutter to trim fabric hems
- * More options on variety of accessories and device for production requirement

Sewtech International

OFFICE: Parkway Trade Center, 4/13, Shalikhura, (Beside Asia Pump), Tongi, Gazipur, Bangladesh.

+880 1748 922 485,

+880 1602 050 011

info@sewtechint.com

J&C Seamless bonding machine

ADHESIVE FILM LAYDOWN MACHINE
JC-6862A



3D FOLD MACHINE (FOR BRA)
JC-8863



ADHESIVE FILM LAYDOWN MACHINE (FOR BRA)
JC-6862B



Sewtech International

OFFICE: Parkway Trade Center, 4/13, Shalikhura, (Beside Asia Pump), Tongi, Gazipur, Bangladesh.

+880 1748 922 485,

+880 1602 050 011

info@sewtechint.com

J&C Seamless bonding machine

ADHESIVE FILM FUSING (FOLD OVER MACHINE)

JC-6852



Description:

- * Upper and lower belts adjust the speed separately
- * Blowing adjust air flow and temperature separately
- * Independent adjustment for heating tank temperature
- * Belts pressure is adjustable
- * Fabric edge finish with trimmer
- * More options on variety of accessories and device for production requirement

DOUBLE CAMERA HIGH SPEED PUR GLUE MACHINE

JC-722S



Description:

- * High uniformity backlight
- * Two high- definition camera
- * Servo drive motor
- * The air pressure of the material valve is adjusted independently
- * Barrel seat temperature can be adjusted independently

Sewtech International

OFFICE: Parkway Trade Center, 4/13, Shalikhura, (Beside Asia Pump), Tongi, Gazipur, Bangladesh.

+880 1748 922 485,

+880 1602 050 011

info@sewtechint.com

FLAT PRESS MACHINE

JC-7090



Description:

- * Double station mobile table, higher production efficiency
- * The temperature and time can be adjusted independently and the automatic constant temperature is more accurate
- * Spring automatic adjustment balance ensure average pressure

Sewtech International

📍 OFFICE: Parkway Trade Center, 4/13, Shalikhura, (Beside Asia Pump), Tongji, Gazipur, Bangladesh.

☎ +880 1748 922 485,

☎ +880 1602 050 011

✉ info@sewtechint.com

SENS.BOND

Seamless bonding adhesive tape



SENS.BOND Seamless Bonding Adhesive Tape

High Recovery Adhesive

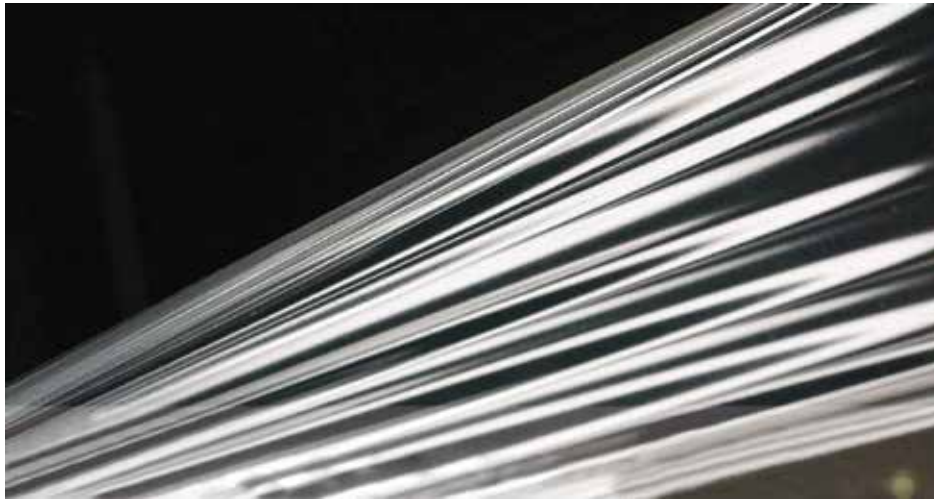

High Tensile Strength

Article	Width	Gauge	Temperature	Pressure	Recovery
6812	1520mm	0.03 0.05 0.08	160-180°C	3.5-5KG	99%
6812C	1520mm	0.05 0.05mm 0.075mm	160-180°C	3.5-5KG	98%
6866	1520mm	0.10mm 0.125mm	150-175°C	3.5-5KG	99%

Low Temperature Adhesive

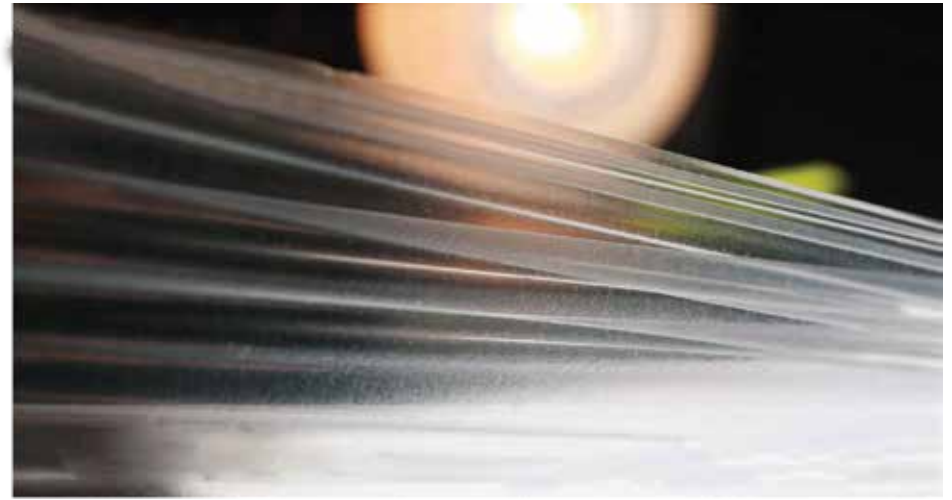

Low Temperature Operation

Article	Width	Gauge	Temperature	Pressure	Recovery
6815A	1520mm	0.05mm 0.075mm	130-160°C	3-4KG	98%
6855D	1520mm	0.05mm 0.08mm 0.1mm	130-160°C	3-4KG	96%
6815C	1520mm	0.05mm 0.075mm 0.1mm 0.12mm	120-150°C	3-4KG	97%
6855C	1520mm	0.05mm 0.08mm	120-160°C	3-4KG	93%

Sewtech International

OFFICE: Parkway Trade Center, 4/13, Shalikhura, (Beside Asia Pump), Tongi, Gazipur, Bangladesh.

+880 1748 922 485,

+880 1602 050 011

info@sewtechint.com

SENS.BOND Seamless Bonding Adhesive Tape

Cushioned Comfort Adhesive Range



Supportive

Article	Width	Gauge	Temperature	Pressure	Recovery
6820C	1500mm	0.3mm 0.35mm 0.50mm 0.70mm 1mm	160-190°C	1.5-2.5KG	99%
6820	1500mm	0.40mm 0.55mm	150-170°C	1.5-2.5KG	99%

Extreme Stretch & Recover Adhesive Range

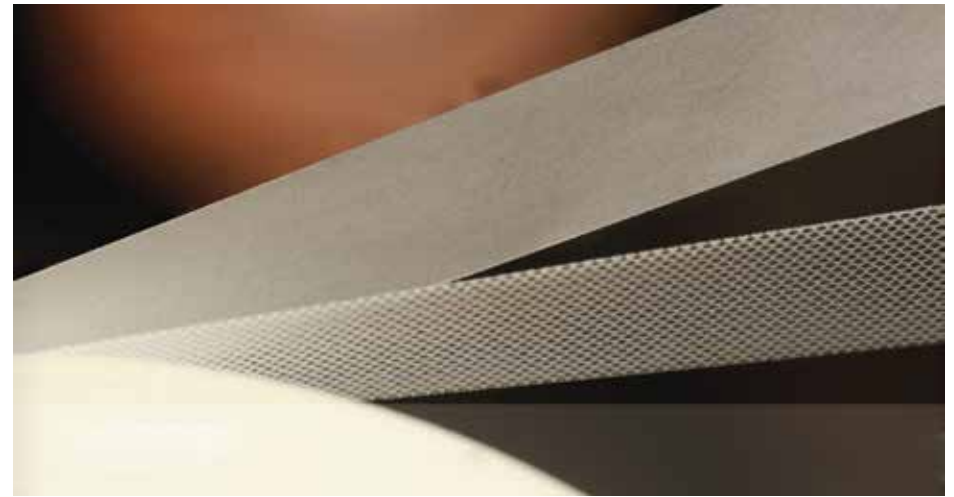

High Recovery

Article	Width	Gauge	Temperature	Pressure	Recovery
6893/45g	1480mm	0.22mm	160-180°C	4-5KG	99%
6893A/45g	1480mm	0.24mm	130-160°C	4-5KG	98%

Sewtech International

OFFICE: Parkway Trade Center, 4/13, Shalikchura, (Beside Asia Pump), Tongi, Gazipur, Bangladesh.

+880 1748 922 485,

+880 1602 050 011

info@sewtechint.com

SENS.BOND Seamless Bonding Adhesive Tape

Good Ari Permeability



Good Ari Permeability

Pur glue



Good Adhesion

Article	Width	Gauge	Temperature	Pressure	Recovery
6877	1500mm	0.7mm	140-170°C	3-4KG	99%
6877A		0.2mm	150-170°C	3-4KG	99%



Sewtech International

OFFICE: Parkway Trade Center, 4/13, Shalikhura, (Beside Asia Pump), Tongi, Gazipur, Bangladesh.

+880 1748 922 485,

+880 1602 050 011

info@sewtechint.com

SEWTECH Computerised peel test machine for bonding

COMPUTERIZED PEEL TEST MACHINE BLD-1026D



The tensile test machine shall meet the requirements of JB 706-77, the Technical Conditions of Mechanical Tension Test Machine.

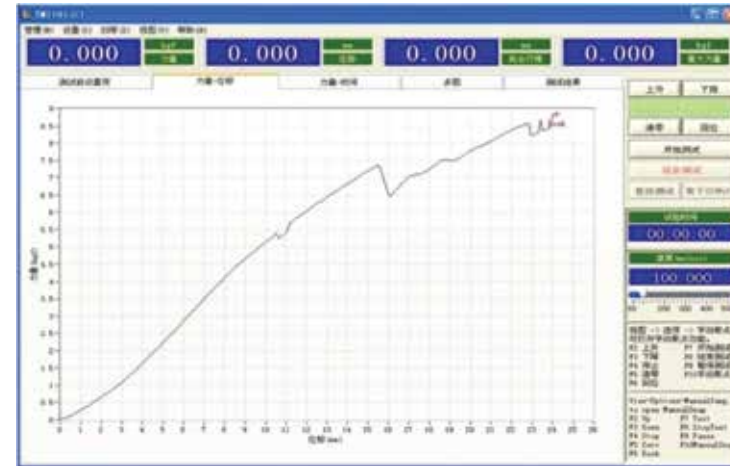

The tension test machine shall be equipped with automatic recording and stripping. The product is designed and manufactured in accordance with the relevant GB17200 specifications. The performance indexes comply with the requirements of GB / T2790 (adhesive 180° peel strength test), GB / T2791 (adhesive T peel strength test), GB2792 (pressure sensitive adhesive tape 180° peel strength test), GB4 (low speed deconvolution strength test), GB7754 (shear strength test), GB8808 (composite film peel strength test), ZBY28004 (thermal sealing strength test), GB13022 (film tensile test), GB7753 (pressure sensitive adhesive tape tensile test) and other test methods. It is suitable for adhesive, adhesive tape, nonadhesive, composite film, artificial leather, woven bag, film, paper and other related products for stripping, shear and pull detection test. Equipment composition:

1. Rico sensor
2. ball screw
3. Bolid control software
4. AC motor
5. synchronous wheel
6. electrostatic spraying paint
7. column aluminum profile
8. computer

Sewtech International

OFFICE: Parkway Trade Center, 4/13, Shalikchura, (Beside Asia Pump), Tongji, Gazipur, Bangladesh.

+880 1748 922 485,

+880 1602 050 011

info@sewtechint.com

EVER GREEN Taiwan Made Ultrasonic Solution

ULTRASONIC LACE SEWING MACHINE



EGR-015



ULTRASONIC CUTTING MACHINE



EGR-015S



EGW-2014~1526



Sewtech International

OFFICE: Parkway Trade Center, 4/13, Shalikhura, (Beside Asia Pump), Tongji, Gazipur, Bangladesh.

+880 1748 922 485,

+880 1602 050 011

info@sewtechint.com

SINGLE BED FLAT BONDING MACHINE



YSNH-2085WF

1. It is suitable for pressing the adhesive tapes of products such as seamless underwear, sportswear, etc.
2. The lower mold is rotated by a cylinder and a damper, reciprocating 180° and the rotation is brisk and stable.
3. Rotating design of the lower mold can simultaneously carry out pressing swinging and rewinding operations, which greatly improves work efficiency.
4. Adopt double cooling vortex fan to cold press mold fast, fast shaping and cooling molds ensure excellent pressing effect

CAROUSEL TYPE TWO BEDS FLAT BONDING MACHINE



YSNH-5065

1. It is suitable for pressing and bonding seamless underwear sportswear and other products with adhesive tape.
2. The upper mold is design to be inverted during pressing using pneumatic cylinder and damper mechanism which helps smoothen the inverted press action
3. vortex blower fan air cooled lower mold is used to quickly finalize cool the work piece to ensure excellent pressing and bonding effect.
4. optimized design, using pneumatic booster cylinder (high pressure) equipped with high sensitivity photoelectric sensor to ensure the safety of workers.

DOUBLE ROLLER FUSING MACHINE



YSNH-Q1000SX/Q1200X/Q1600SX

DIAMOND NEW TYPE FUSING MACHINE



YSNH-Q900Z/Q1000Z

DIAMOND NEW TYPE FUSING MACHINE



YSNH-Q1600S/1800S

SEAM OF BACK SIDE PRESSS MACHINE



YSZT-5035

Sewtech International

OFFICE: Parkway Trade Center, 4/13, Shalikhura, (Beside Asia Pump), Tongji, Gazipur, Bangladesh.

+880 1748 922 485,

+880 1602 050 011

info@sewtechint.com

NIKKA NEEDLE DETECTOR

NJ-series

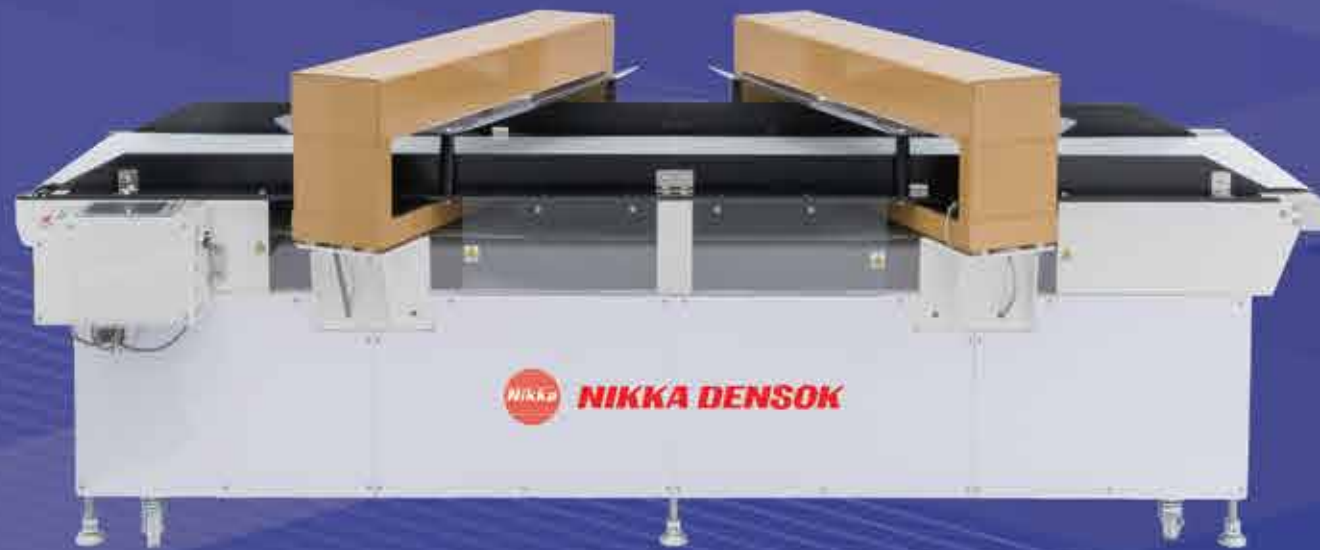



BRA MOLDING SOLUTION

MOLD CLASSIFICATION

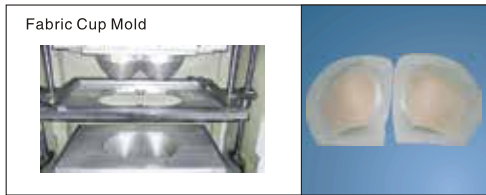

Sewtech International

OFFICE: Parkway Trade Center, 4/13, Shalikhura, (Beside Asia Pump), Tongi, Gazipur, Bangladesh.

+880 1748 922 485,

+880 1602 050 011

info@sewtechint.com

YILI Bra molding solution

Multi-Feature Molding Machine (Three Mold)

YL-8560



Bra Pad Molding Machine

YL A2-A



Bra Pad Molding Machine



YL-8565

Technical parameters

Power	AC220V/4.5KW
Compressed air	0.4-0.8Mpa
Molding time	0-999s
Mold platform size	450 x 220mm
External dimensions	820 x 900 x2035(2335)mm
Seal activity door	have
Weight	306Kg

Sewtech International

OFFICE: Parkway Trade Center, 4/13, Shalikchura, (Beside Asia Pump), Tongji, Gazipur, Bangladesh.

+880 1748 922 485,

+880 1602 050 011

info@sewtechint.com

FN-360HRT

360 Head Rotating Template Sewing Machine



High rigidity of one-piece foundry head, reinforced mesh ribs inside the head.



Adopt huge base structure, ensure the machine working stable and never deformation.



Equipped with servo control technology, runs more smoothly and accurately, empty moves faster.



Servo motor direct drive screw rod, ensure high transmission accuracy, good stability, not easy to aging.

Sewtech International

OFFICE: Parkway Trade Center, 4/13, Shalikhura, (Beside Asia Pump), Tongji, Gazipur, Bangladesh.

+880 1748 922 485,

+880 1602 050 011

info@sewtechint.com

AMM Customize Automation



SEWTECH

Innovate. Automate. Serve.



SEWTECH Brand Automatic Machine For Shirt

Automatic double head elastic rubber bend ultrasonic welding, stitching machine 3 in 1 (ultrasonic welding & logo benchmarking)

ST - M - 101



Welding before sewing, 750 to 900 splices per hour

Technical Parameters

Model Specification	ST - TJ - YX	
Nose	1510	JUKIAM-210EN Series
Power	450W-1000W	450W-1000W
Use Power	220V/60Hz 220/Single Phase 50/60Hz	
Use Air Pressure	0.4-0.6 Mpa (0.4KGF/CM ²)	
Machine Needle	DPX5 (11#,12#)	
Control System	NC Control	
Sewing Machine Speed	2700RPM (MAX)	
Rubber Band Sewing Width	20mm-50mm	
Minimum Folded Length	150MM	
Measurement Output System	Servo motor	

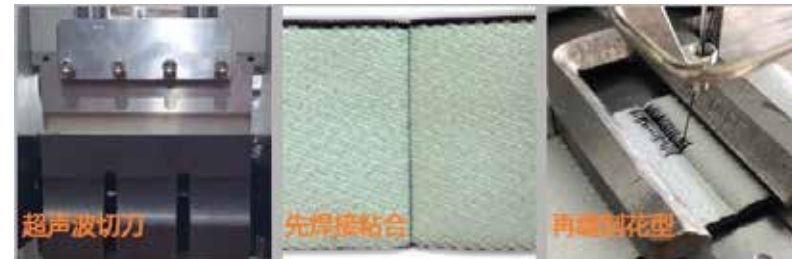

- * The above models are for reference only, please consult for details
- * For the sake of improvement product specifications are subject to change without notice

Sewtech International

OFFICE: Parkway Trade Center, 4/13, Shalikchura, (Beside Asia Pump), Tongji, Gazipur, Bangladesh.

+880 1748 922 485,

+880 1602 050 011

info@sewtechint.com

SEWTECH Brand Automatic Machine For Bra

Automatic overlock rubber band splicing/ringer machine
(focusing on tendon wrapping process and sewing
with overlock sewing machine)

ST - M - 102



Double strip splicing (1 to 4 cm wide rubber band)
splicing 1200-1500 pieces per hour

Main Function

- Compatible with all brands of overlock sewing machines
- Automatic identification of rubber joint and automatic cutting off
- Automatic shutdown alarm without needle and thread or rubber band
- Automatic counter
- Single optional wrapping head function

Reinforcement Wrapping Process



Overlock Sewing



Sewtech International

OFFICE: Parkway Trade Center, 4/13, Shalikhura, (Beside Asia Pump), Tongji, Gazipur, Bangladesh.

+880 1748 922 485,

+880 1602 050 011

info@sewtechint.com

SEWTECH Brand Automatic Machine For Shirt

AUTO COLLAR ATTACHING MACHINE

ST-M-103



One machine with multiple functions



T-shirts round neck



Rib round waist



Elastic cuff

AUTO RIB CUFF ATTACHING MACHINE

ST-M-104



New generation, new performance



Sewtech International

OFFICE: Parkway Trade Center, 4/13, Shalikchura, (Beside Asia Pump), Tongi, Gazipur, Bangladesh.

+880 1748 922 485,

+880 1602 050 011

info@sewtechint.com

SEWTECH Brand Automatic Machine For Bra

AUTO CUT AND RE-ENTRY MACHINE

ST - M - 105



Independent of skilled workers, automatic section change
Automatic belt cutting, feeding and thread cutting



AUTOMATIC POLO SHIRT PLACKET
BUTTON HOLIDING MACHINE

ST - M - 106



Initiative technology
Horizontal and vertical button holing.



AUTOMATIC POLO SHIRT PLACKET
BUTTON STITCH MACHINE

ST - M - 107



Auto button feeding and attaching



Sewtech International

OFFICE: Parkway Trade Center, 4/13, Shalikhura, (Beside Asia Pump), Tongi, Gazipur, Bangladesh.

+880 1748 922 485,

+880 1602 050 011

info@sewtechint.com

SEWTECH Brand Automatic Machine For Shirt

Full automatic laser cutting pocket
welting/opening machine

ST - M - 108



Sewtech International

OFFICE: Parkway Trade Center, 4/13, Shalikchura, (Beside Asia Pump), Tongi, Gazipur, Bangladesh.

+880 1748 922 485,

+880 1602 050 011

info@sewtechint.com

SEWTECH Brand Automatic Machine For Bra





Full automatic ultrasonic welding shoulder-strap machine (2 in1)



ST-M-109

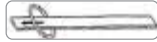

Process

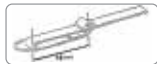
- ① Putting the strap through a round ring. 
- ② Cutting strap in set lengths. 
- ③ Putting the strap through the 8 ring. 
- ④ Sewing or ultrasonic welding 
- ⑤ Putting the strap through the 8 ring again. 
- ⑥ Finish the strap and stacking adjusted to 50mm 







Full automatic ultrasonic welding shoulder-strap machine (2 in1)



ST-M-110



Process

- ① Putting the strap through a round ring. 
- ② Cutting strap in set lengths. 
- ③ Putting the strap through the 8 ring. 
- ④ Size after completion of sewing 
- ⑤ Putting the strap through the 8 ring again. 
- ⑥ Finish the strap and stacking adjusted to 50mm 



Semi-automatic bra straps machine (back-single)



ST-M-111

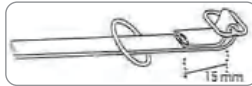

Process

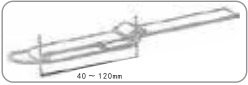
- ① Start 
- ② It lets through an 8 ring. 
- ③ It builds the size of the adjuster part into 40~120mm. 

Sewtech International

OFFICE: Parkway Trade Center, 4/13, Shalikhura, (Beside Asia Pump), Tongi, Gazipur, Bangladesh.

+880 1748 922 485,

+880 1602 050 011

info@sewtechint.com

SEWTECH Brand Automatic Machine For Shirt

ST-M-112



自然弧度的领型
Vivid Collar

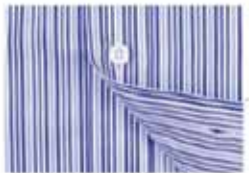

平整的门筒里襟
Flat Placket



下摆不起豆角

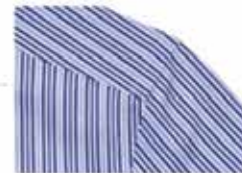

平整的肩位
Flat shoulder stitches

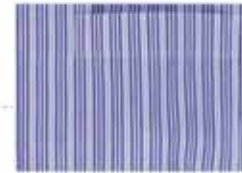

平整的袋子，浑然一体
pocket integrated with the frontpart



平整弧形下摆
P f t c d hem



Sewtech International

OFFICE: Parkway Trade Center, 4/13, Shalikhura, (Beside Asia Pump), Tongji, Gazipur, Bangladesh.

+880 1748 922 485,

+880 1602 050 011

info@sewtechint.com

SEWTECH Brand Automatic Machine For Bra

**AUTOMATIC BACK PLACKET SINGLE NEEDLE
STITCHING MACHINE**

ST - M - 113



**AUTOMATIC SEWING MACHINE FOR
PLACKET BUTTONHOLING**

ST - M - 114



**AUTOMATIC SEWING MACHINE FOR
FRONT BUTTON STAY**

ST - M - 115



**AUTOMATIC SEWING MACHINE FOR FRONT BUTTON
STAY WITH CAMERA**

ST - M - 116



Sewtech International

OFFICE: Parkway Trade Center, 4/13, Shalikhura, (Beside Asia Pump), Tongji, Gazipur, Bangladesh.

+880 1748 922 485,

+880 1602 050 011

info@sewtechint.com

SEWTECH Brand Automatic Machine For Shirt

Ribbon Cutting Machine

CUTTING(SLITTER)MACHINE SERIES

JN-888S-2
JN-888SL-2
JN-888SLL-2

COMPUTER FULL AUTOMATIC CUTTING (SLITTER) MACHINE

JN-888S-3
JN-888SL-3
JN-888SLL-3

COMPUTER FULL AUTOMATIC CUTTING (SLITTER) MACHINE

- ▶ Pneumatic clamping device, infrared sensor automatically detects the diameter and length of the fabric, and the cutter Y-axis feed amount is automatically sensed.
- ▶ Automatic detection system of cutter diameter, adjust the feed of cutter at any time.

(IT SUITABLE FOR CUTTING FABRIC, CHEMICAL FABRIC, RUBBERIZED FABRIC, ADHESIVE TAPE, LEATHER, PAPER, INTELINING, ETC)

Features:

1. Controlled by microcomputer digital programming technology, touch screen working interface, it is easy and convenient to operate.
2. With full cover safety door design and automatic dust collection device for knife sharpening, to make sure the operation be more safer and environment protection.
3. Uniquely designed of knife sharpening device, the sensor monitors the knife position at real time, it can set to grind the knife at any time in order to make the knife keep sharp
4. Automatic resetting to original location after finish cutting and self elevation unit locking structure for end of the main shaft to decrease labour strength.
5. The same rolled fabric can be cut out six different width binding tapes..
6. The revolving speed of main shaft & cutter and the moving speed of X shaft & Y shaft can be set freely. (Double servo motors)



ST-M-117

Sewtech International

OFFICE: Parkway Trade Center, 4/13, Shalikchura, (Beside Asia Pump), Tongi, Gazipur, Bangladesh.

+880 1748 922 485,

+880 1602 050 011

info@sewtechint.com

SEWTECH Shell Stitch Machine

Shell Stitch Machine



ST-M-118

Large Shell Stitch Overlock Sewing Machine

This machine is made in various specific styes of producing shell edge finish of different size

Large Shell Stitch Pattern



Model	Speed	(8b2) Torms	7(mh2) size	Seam Width	Needle
GC318	1200	4.0/6.0/8.0	2-3.9mm	Adjustable 2-5.0mm	Organ HAX1/SPG#16 10#
GC320	970	6.0/8.0/12.0	2-5.0mm	Adjustable 2-5.0mm	Organ HAX1/SPG#16 10#
GC328	750	10.0 mm	Medium	Broad	Organ HAX2/SPG#16 Organ HAX2/SPG#150 /BGG#16

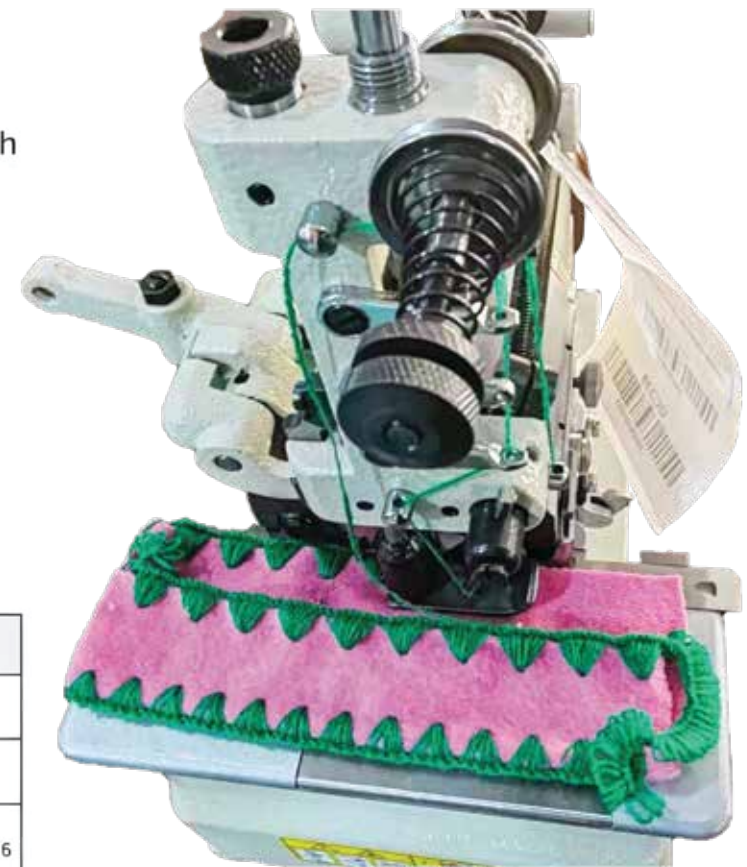

Sewtech International

OFFICE: Parkway Trade Center, 4/13, Shalikhura, (Beside Asia Pump), Tongi, Gazipur, Bangladesh.

+880 1748 922 485,

+880 1602 050 011

info@sewtechint.com

SEWTECH

Innovate. Automate. Serve.

DEVICES



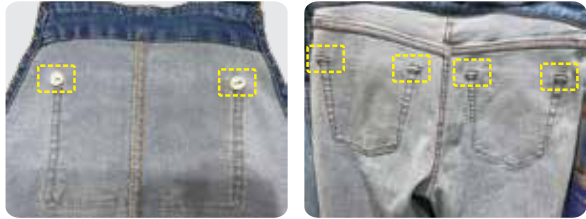

⦿ Automatic Clothing-label Machine

⦿ Automatic Lining Reinforcement Cutting-sewing Machine(Bar-tacking)



⦿ Automatic Lining Reinforcement Cutting-sewing Machine(Button)

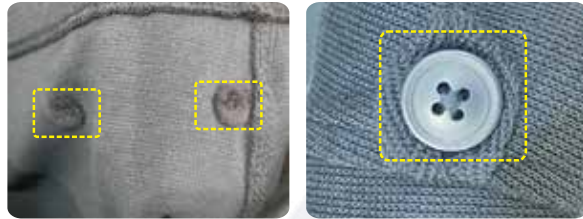

⦿ Automatic Cutting-sewing Velcro Machine

SEWTECH

Innovate. Automate. Serve.

⦿ Automatic Sewing Darts And Waist Pleats Machine

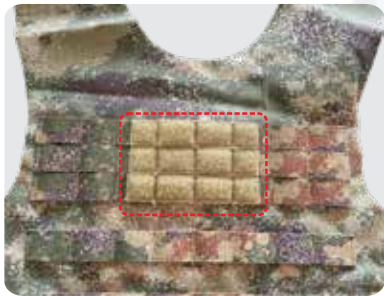

⦿ Bar-tacking Machine With Auto Suction Trimmer Device

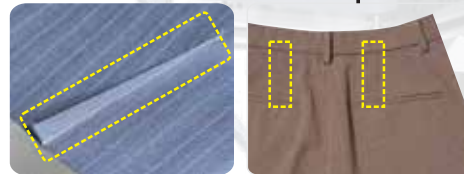

⦿ Straight Button-hole Machine With Auto-feeder (Multi-hole)



⦿ Straight Button-hole Machine With Auto-feeder (Two Holes)



⦿ Automatic String Thrusting Machine



Automatic button feeder (Pen cylinder)

Feeding button 120 times per minute, button range: 8-25mm;
Optional machinery: 1903, 438, 373, 4-2;
Voltage: 220V 50-60Hz;
Packing size: 58×55×46cm, Gross Weight: 33kg

ST-D-101



Sewtech International

OFFICE: Parkway Trade Center, 4/13, Shalikhura, (Beside Asia Pump), Tongji, Gazipur, Bangladesh.

+880 1748 922 485,

+880 1602 050 011

info@sewtechint.com

Vertack Bird's Nest Prevention Device

the device prevents the bird's nest that occurs on a bartacking sewing machine at the start of sewing. and through the patented thread cutting structure, cut off redundant surface line so as to improve the quality of clothing and reduce the process of thread cutting.



ST-D-102



Fabric residual sewing thread



Bird's nest on the bottom



Surface thread without thread end

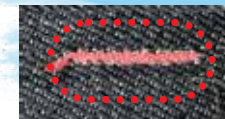

No bird nest under the cloth

Needle Thread Trimming Mechanism

The razor type thread cutting mechanism is installed which is more durable and safe and will not cause damage to the cloth



Intelligent and humanized design

Whether it is in the sewing process, when it touches the high bottom and bone position of the cloth or when it circulates the pattern it does not need the technician to adjust it again and the cutter position automatically adapts.

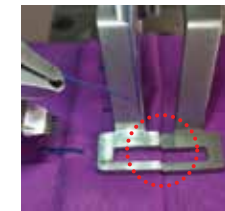
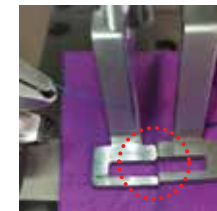

Fabric residual sewing thread



Bird's nest on the bottom

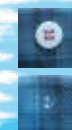

Surface thread without thread end



No bird nest under the cloth

Sewtech International

OFFICE: Parkway Trade Center, 4/13, Shalikhura, (Beside Asia Pump), Tongi, Gazipur, Bangladesh.

+880 1748 922 485,

+880 1602 050 011

info@sewtechint.com

Single Needle Bird's Nest Equipment



ST-D-103

No Thread Lumps Equipment
Avoid thread lumps, keep high quality!
 (suitable for all computer lockstitch machine)

High performance of avoiding the thread lumps when sewing the label
 - all kinds of top stitching and also can totally avoid the thread lumps caused by first stitches which caused by the automatic cutting and sewing machine. Really professional and reliable helper of high quality cloth.

Suitable for all electronic flat sewing machines

Improving 40% production efficiency for label sewing

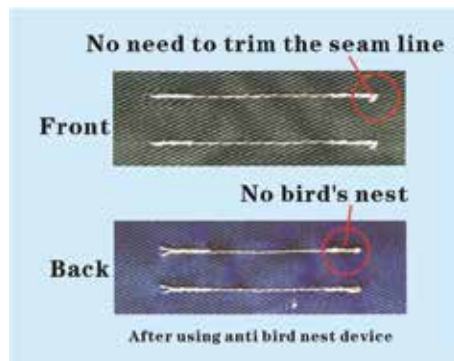
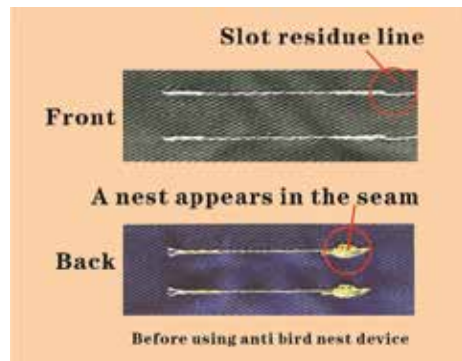
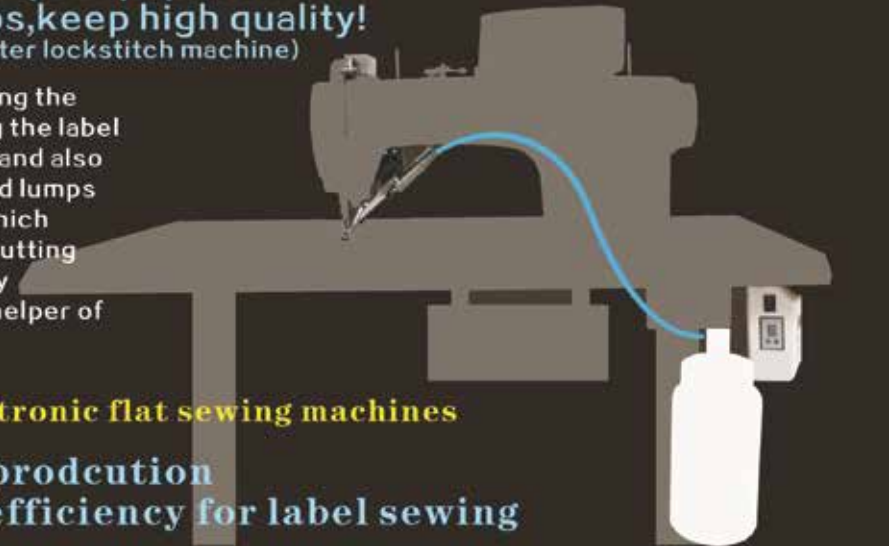

Avoid the thread lumps caused by first stitches

Avoid the thread lumps equip with professional thread hooking device which can keep the thread stitches flat on the bottom side of the cloth, no more thread lumps or cut thread process



Voitage: 100-265VAC
Frequency: AC50/60HZ

Rope Folding Device



ST-D-104



Micro Computer Bra Swan Hook Folding Loop Cut and Attaching Machine



Traditional	VS	MCT Automation
1 Cut		Cut, send and fold in one
2 Manually hold bartack		 <p>Strap material is saved by 35% Efficiency is increase by 40% Quality is increase by 85%</p> <p>7200 bartack per person in 10 hours (90-stitches lock and folded)</p>
3 Manually fold fixed		
4 Manually cut repairing		
5 Manually lock bartack		
5 Operation total time 20seconds		

ST-D-105

Bra-wire insert machine



ST-D-106



Corset



Bra



Swimsuit

By relying on the strength of worker to push with thier hands, severe finger injury and low efficiency

VS

Other Brand

Manuel Feed

After the final feeding, it is necessary to manually push agian because the 3cm end of the steel ring is not completely feed into the underwear

Take the size of the conventional steel ring as an example,as shown in the figure below

High efficiency,save process

Calculated by 10 hours a day, 6000 steel rings can be worn

one machine is equivalent to 2-3 workers

Feed and insert in one time

Compatible with variety of materials



Compatible with various steel ring size specifications



Compatible with various bra size specifications

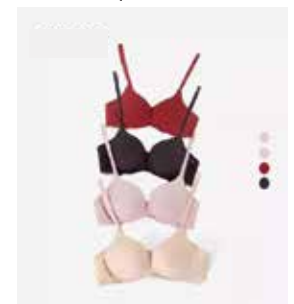

Bra bon insert machine



ST-D-107

Wearing plastic strips/steel strips "artifact"

Escort your body shaping & s ports

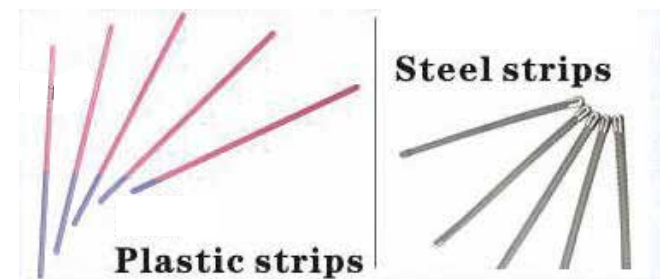

Automatic Hangtag Labeller/Printer



ST - D - 108

Sewing machine (synchronous belt model)



ST - D - 109

Sewtech International

OFFICE: Parkway Trade Center, 4/13, Shalikchura, (Beside Asia Pump), Tongji, Gazipur, Bangladesh.

+880 1748 922 485,

+880 1602 050 011

info@sewtechint.com

Spaghetti Device

ST-D-110



Sewtech International

OFFICE: Parkway Trade Center, 4/13, Shalikhura, (Beside Asia Pump), Tongi, Gazipur, Bangladesh.

+880 1748 922 485,

+880 1602 050 011

info@sewtechint.com

Ultrasonic Tracking Machine



Ultrasonic Point Tacking Machine

ST-D-111



Automatic Lining Reinforcement Cutting-sewing Machine (Bar-tacking)



ST-D-112



Straight Button-hole Machine With Auto-feeder and Lining (Two-hole)



ST-D-113



Sewtech International

OFFICE: Parkway Trade Center, 4/13, Shalikhura, (Beside Asia Pump), Tongi, Gazipur, Bangladesh.

+880 1748 922 485,

+880 1602 050 011

info@sewtechint.com

Computerized electronic tension device



ST-D-114

Computerized electronic tension device



ST-D-115



It is suitable for the sewing control of the size of various high elastic fabrics, such as underwear, underwear swimwear, Sportswear, home clothing, etc

Direct drive motor automatic
induction tape cutting device
(with interlock sewing machine)



ST-D-116

Loop Cutter Device



ST-D-117

Semi automatic hem folding device



ST-D-118

Ultrasonic Tape Cutting Machine



ST-D-119

Cap Punch Device



ST-D-120

Winding Machine



ST-D-121

Sewtech International

OFFICE: Parkway Trade Center, 4/13, Shalikhura, (Beside Asia Pump), Tongi, Gazipur, Bangladesh.

+880 1748 922 485,

+880 1602 050 011

info@sewtechint.com

Spaghetti Device



ST-D-122

Send Elastic Bands Machine



ST-D-123

Single Needle/Two Needle
Back Puller Device



ST-D-124

Single needle/Two Needle
Backpuller Device

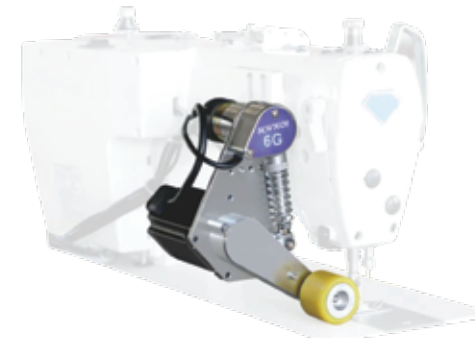

ST-D-125

Sewtech International

OFFICE: Parkway Trade Center, 4/13, Shalikhura, (Beside Asia Pump), Tongji, Gazipur, Bangladesh.

+880 1748 922 485,

+880 1602 050 011

info@sewtechint.com

**Single needle/Two Needle
Back Puller Device**

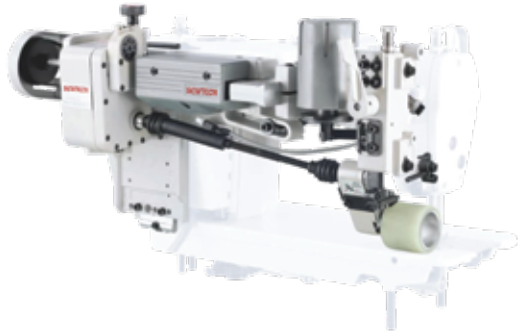

ST-D-126

Flatbed back puller device



ST-D-127

BOWL CAR SPECIAL (STANDARD)



ST-D-128

Package sewn car, up and down tug drive



ST-D-129

Automatic Cutting-Sewing Velcro Machine



ST-D-130

Automatic sewing darts and Waist Pleats Machine



ST-D-131

Bra-tacking machine with auto suction trimmer device



ST-D-132

Automatic Strip Fold Sewing Device



ST-D-133

Pneumatic Side Cutter

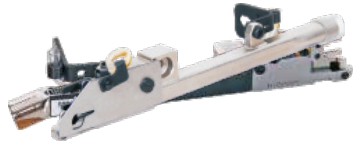

ST-D-134



ST-D-135



ST-D-136

Pneumatic Flat Cutter



ST-D-137



ST-D-138



ST-D-139



ST-D-140



ST-D-141

Thread Trimming Machine

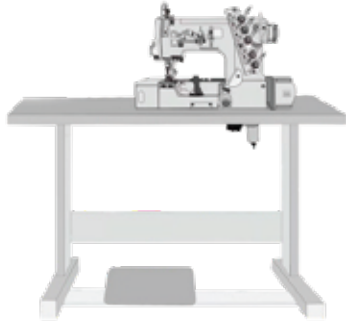

ST-D-142

Automatic Hem Folding Device



ST-D-143

Thread Trimming Machine



ST-D-144

Suction and Blowing Integrated Dust Collecting Gun



ST-D-146

Industrial electric scissors



ST-D-145

SEWTECH Devices

Overlock Pneumatic Anti-Curler Device



ST-D-147

Pneumatic double package wasit faucel



ST-D-148

Blind Sewing Machine
Automatic Thread Trimming



ST-D-149

Overlock Seam Presser Foot
Micro-adjustment Device



ST-D-150

Pneumatic Cuff Roller Assist Device



ST-D-151

Scissor sharpening machine
series (special model for blades)



ST-D-152

Sewtech International

OFFICE: Parkway Trade Center, 4/13, Shalikchura, (Beside Asia Pump), Tongi, Gazipur, Bangladesh.

+880 1748 922 485,

+880 1602 050 011

info@sewtechint.com

Tubular extending roller set



ST-D-153

Tubular extending roller set



ST-D-154

Overlock Pneumatic roller
Auxiliary spreading device



ST-D-155

Tubular extending roller set



ST-D-156

Pneumatic cuff roller
assist device



ST-D-157

Pneumatic roller spreading device
(simple style)



ST-D-158

SEWTECH Devices

Dd Motor Auto Induction Tape Cutting Device (With Coverstitch)



ST-D-159

DD motor auto induction tape cutting device (with zig-zig)

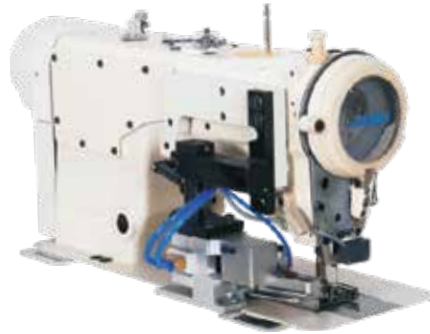

ST-D-160

Tape cutter device (with lockstitch/double needle)



CTP-3 Cutter

ST-D-161

Automatic Feeding & Hot Cutting Device



ST-D-162

Tape Cutting Device



ST-D-163

DD motor auto induction tape cutting device (with double needle machine)



ST-D-164

Sewtech International

OFFICE: Parkway Trade Center, 4/13, Shalikhura, (Beside Asia Pump), Tongi, Gazipur, Bangladesh.

+880 1748 922 485,

+880 1602 050 011

info@sewtechint.com

SEWTECH Devices

Computerized Automatic Tape Cutting and Re-enter device



ST-D-165

Computerized Automatic Tape Cutting and Re-enter device



ST-D-166

Computerized electronic tension device



ST-D-167

Computerized electronic tension device



ST-D-168

Computerized electronic tension device



ST-D-169

Semi-Automatic End Cutting Machine



ST-D-170

Sewtech International

OFFICE: Parkway Trade Center, 4/13, Shalikhura, (Beside Asia Pump), Tongi, Gazipur, Bangladesh.

+880 1748 922 485,

+880 1602 050 011

info@sewtechint.com

Single color link cup Pad Printer



ST-D-171

Rope Insert Machine



ST-D-172

Laser Cutting Machine



ST-D-173

Label Cutting Machine



ST-D-174

Automatic Rotary Cutting Machine



ST-D-175

Elastic Cutting Machine



ST-D-176

Fixed Roller Set



ST-D-177

Tubular extending roller set
(Extend version)



ST-D-178

Tubular Extending
Roller Set



ST-D-179

Tubular Extending
Roller Set



ST-D-180

Tubular extending
Roller set



ST-D-181

Right Knife Tubular Extending
Roller Set



ST-D-182

Ring Ribbed Cuffs
With Elasticated Overlock



ST-D-183

Tubular Extending
Roller Set (Pneumatic)



ST-D-184



DAWN SING



DAWN SING Dawnsing automatic thread trimming device

Interlock sewing machine

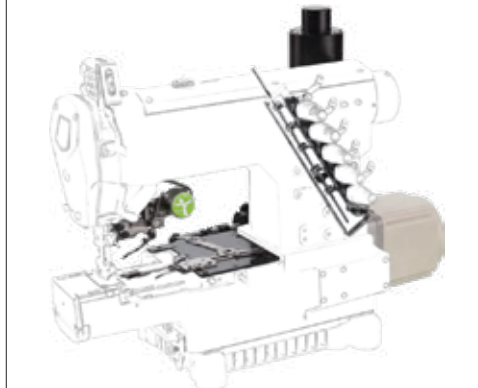

Bartacking sewing machine

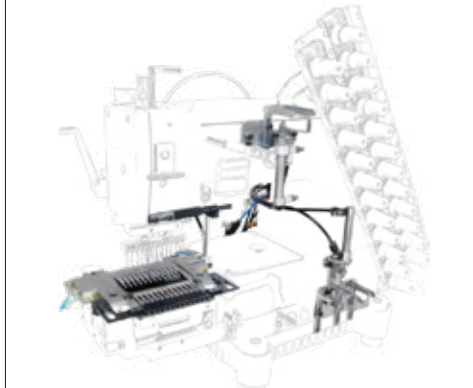

4- needle 6-Thread Flat Seamer Machine

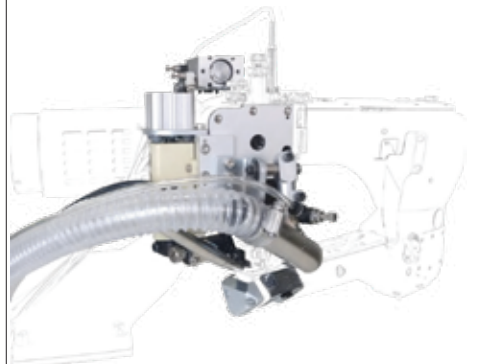

Multi- Needle sewing machine



Servo Motor & Control Box



Dawnsing Electrical Motor



Dawnsing Electrical Motor



Washeng Electrical Motor



HS Electrical Motor

Sewtech International

OFFICE: Parkway Trade Center, 4/13, Shalikhura, (Beside Asia Pump), Tongi, Gazipur, Bangladesh.

+880 1748 922 485,

+880 1602 050 011

info@sewtechint.com

DAWN SING Dawnsing automatic thread trimming device



Sewtech International

OFFICE: Parkway Trade Center, 4/13, Shalikhura, (Beside Asia Pump), Tongi, Gazipur, Bangladesh.

+880 1748 922 485,

+880 1602 050 011

info@sewtechint.com

JUKI 7923



YAMATO VF2500



Brother 430F Bartacking Sewing Machine



Knife Carrier





STI

FOR BROTHER

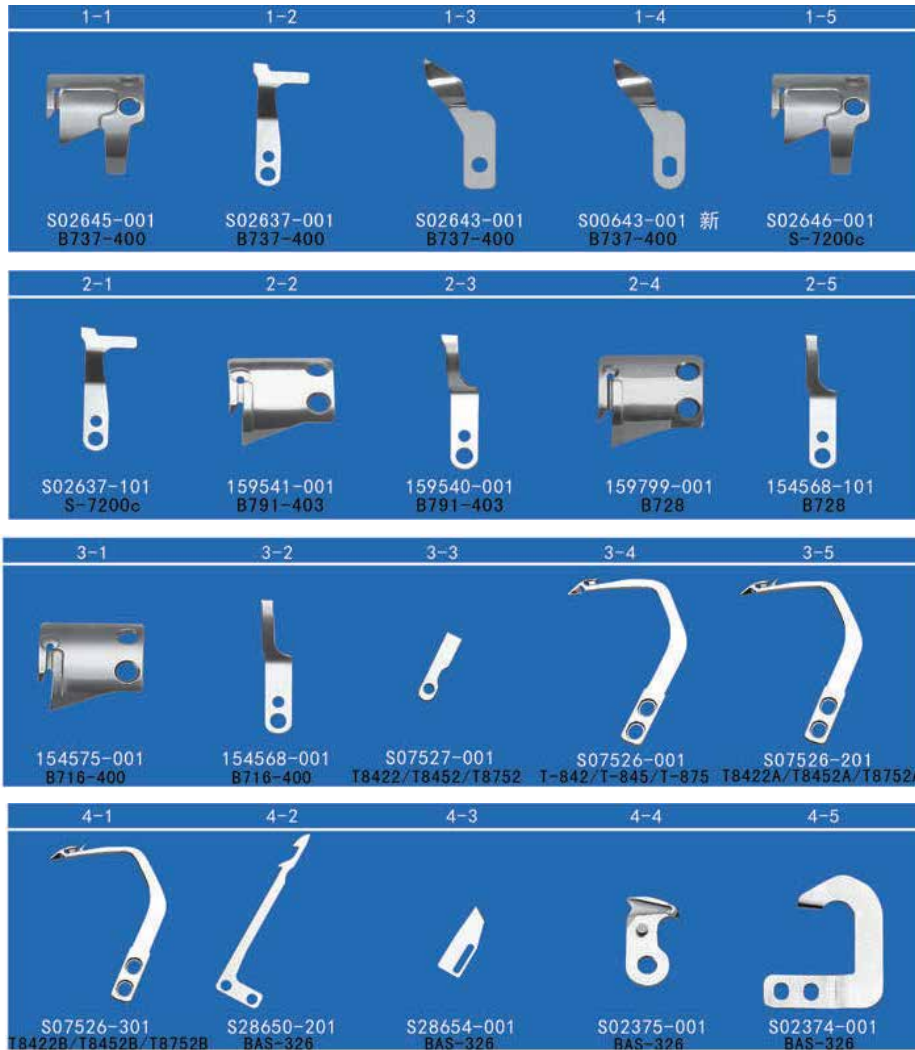

FOR SUN STAR



FOR TOYOTA

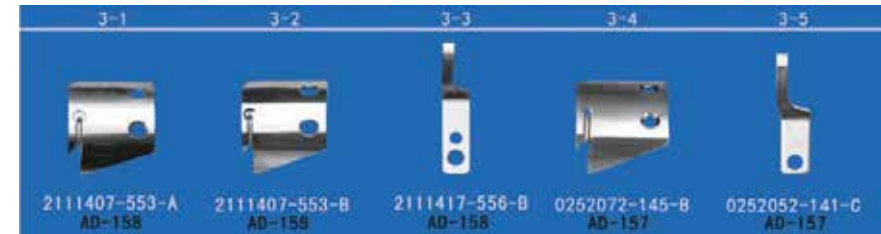

FOR TAJIMA

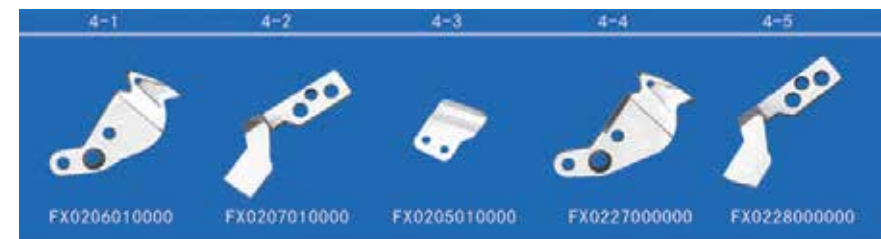

Sewtech International

OFFICE: Parkway Trade Center, 4/13, Shalikhura, (Beside Asia Pump), Tongi, Gazipur, Bangladesh.

+880 1748 922 485,

+880 1602 050 011

info@sewtechint.com

STI Special Pressure Foot



JY333-3



JY333-2



JY69LH-3 1/8



JY69LH-3 1/16



JY69LH-3 1/4



JY69RH-3 1/16



JY69RH-4 1/16



JYA10-3 KX



JY1/32RH-3



JY1/32RH-4



JY1/32LH-1



W500



JY257321A64-3



JY257321A56-3



JY64041A56-3

Sewtech International

OFFICE: Parkway Trade Center, 4/13, Shalikchura, (Beside Asia Pump), Tongi, Gazipur, Bangladesh.

+880 1748 922 485,

+880 1602 050 011

info@sewtechint.com

STI Special Pressure Foot



JY313C



JY



JYSP-18L-2 3/16



JY36N-2



JY361-2



JYNL-31S-3



JYT3-2



JY3611-3



R212



P733



5535

Sewtech International

OFFICE: Parkway Trade Center, 4/13, Shalikhura, (Beside Asia Pump), Tongi, Gazipur, Bangladesh.

+880 1748 922 485,

+880 1602 050 011

info@sewtechint.com

STI Special Pressure Foot

Plastic Base P351



Plastic Presser Feet For Gantry Trucks



Cord-Embedded Presser Foot



Sewtech International

OFFICE: Parkway Trade Center, 4/13, Shalikhura, (Beside Asia Pump), Tongi, Gazipur, Bangladesh.

+880 1748 922 485,

+880 1602 050 011

info@sewtechint.com

STI Special Pressure Foot

P351 (Large)



A10 (small size)



P36N S Single Side



P353 toothpicks



P360 (F0)



P351 (Three-wheeled)



A10 (small size)



P36N S Single Side



P351 small tricycle footrest



P361 (S1)



T58N(F5)



Sewtech International

OFFICE: Parkway Trade Center, 4/13, Shalikhura, (Beside Asia Pump), Tongi, Gazipur, Bangladesh.

+880 1748 922 485,

+880 1602 050 011

info@sewtechint.com

STI Special Pressure Foot



Sewtech International

OFFICE: Parkway Trade Center, 4/13, Shalikchura, (Beside Asia Pump), Tongi, Gazipur, Bangladesh.

+880 1748 922 485,

+880 1602 050 011

info@sewtechint.com

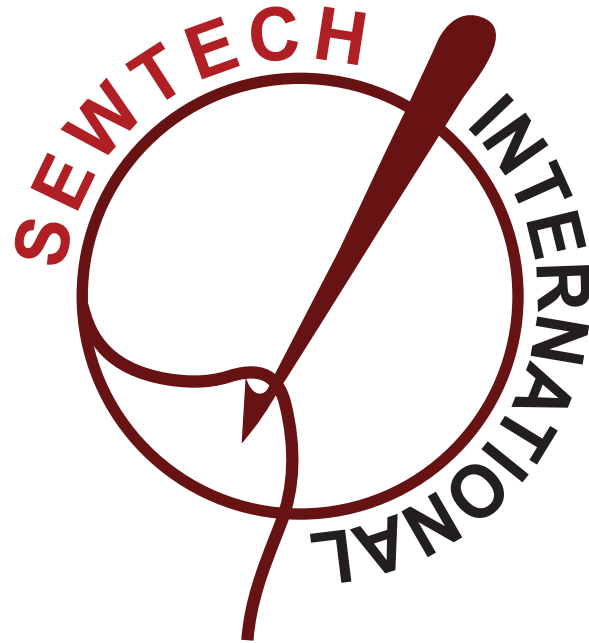

Sewtech International

YOUR TECHNOLOGY PARTNER

Sewtech International

📍 OFFICE: Parkway Trade Center, 4/13, Shalikchura, (Beside Asia Pump), Tongi, Gazipur, Bangladesh.

☎ +880 1748 922 485,

☎ +880 1602 050 011

✉ info@sewtechint.com